

PEREGRINE



OWNERS MANUAL

ZONE RV

TABLE OF CONTENTS

COUPLINGS.....	3
CRUSIEMASTER DO35.....	3
CRUSIEMASTER DO45	4
TRAILER PLUG CONFIGURATION	5
GAS SYSTEM.....	6
REDARC DIGITAL MANAGEMENT SYSTEM	8
REDARC REDVISION DISPLAY – MOBILE APP	9
REDVISION TOTAL VEHICLE MANAGEMENT SYSTEM.....	10
INVERTER.....	11
CHARGER.....	12
240 RCD SWITCH SCHEMATIC.....	13
PLUMBING SCHEMATIC	14
PLUMBING GENERAL.....	16
SEAFLOW EXTERNAL WATER PUMP.....	20
COMPRESSOR FRIDGE/ FREEZER.....	21
ENTERTAINMENT ACCESSORIES.....	22
SUSPENSION SYSTEM.....	23
CRUISEMASTER XT SUSPENSION	24
CRUISEMASTER ATX SUSPENSION	25
AIRBAG CONTROL PANEL – MANUAL LEVELING	28
AIRBAG CONTROL PANEL – AUTO LEVELING AIR BAGS.	29
MAINTENANCE	30
.....	31
PREPARING FOR OFF-ROAD.....	34
DRIVING RECOMMENDATIONS.....	35
DEPARTURE CHECKLIST.....	37
AFTER-SALES SERVICE DEPT CONTACT.....	39
DISCLAIMER.....	40
CUSTOMER NOTES.....	41



COUPLINGS



CRUISE MASTER

CRUSIEMASTER DO35



COUPLING:

1. The caravan should only be coupled on level ground
2. Make sure towing pin and universal is free of sand, dirt and foreign objects, and is lightly lubricated
3. Raise height of trailer coupling above vehicle towing pin by adjusting the RV jack
4. Push and hold lock button down, push the locking plate back to fully open position until the lock button springs back
5. Align coupling over towing pin by moving either vehicle or trailer, and lower.
6. Ensure that the hitch is seated properly on the pin
7. Push the lock button to release the plate into the locked position
8. Assemble the dust cover by snapping in the back edge of the seal first and then pushing on the front
9. Dust cover will emit an audible snap when assembled correctly
10. Release handbrake

UN-COUPLING:

1. Trailer should only be uncoupled on level ground
2. If uneven surface, leave the chains on until finished unhitching the caravan.
3. Engage handbrake and chock wheels if required
4. Remove dust cover, tow plug, camera lead, brake-safe lanyard and safety chains
5. Push and hold lock button down, push the lock plate to fully open position until the lock button springs back
6. Lower jack leg to raise the height of trailer above vehicle towing pin

COUPLINGS



CRUISE MASTER

CRUSIEMASTER DO45



COUPLING:

1. The caravan should only be coupled on level ground
2. Make sure towing pin and universal is free of sand, dirt and foreign objects, and is lightly lubricated
3. Raise height of trailer coupling above vehicle towing pin by adjusting the RV jack.
4. Push and hold lock button down, push the locking plate back to full open position until the lock button springs back
5. Align coupling over towing pin by moving either vehicle or trailer, and lower.
6. Ensure that the hitch is seated properly on the pin
7. Push the lock button to release the plate into the locked position
8. Assemble the dust cover by snapping in the back edge of the self stand then pushing on the front
9. Dust cover will emit an audible snap when assembled correctly
10. Release handbrake

UN-COUPLING:

1. Trailer should only be uncoupled on level ground
2. If uneven surface, leave the chains on until last
3. Engage handbrake and chock wheels if required
4. Remove dust cover, tow plug, camera lead, brake-safe lanyard and safety chains
5. Push and hold lock button down, push the lock plate to full open position until the lock button springs back
6. Lower jack leg to raise the height of trailer above vehicle towing pin

TRAILER PLUG CONFIGURATION

7 PIN FLAT PLUG

PIN No.	CIRCUIT	CABLE	COLOUR
1	Left-hand turn	ECA3 1.13	Yellow
2	Reversing signal		Black
3	Earth return	ECA5 3.25	White
4	Right-hand turn	ECA3 1.13	Green
5	Service brakes	ECA5 3.25	Blue
6	Stop lamps	ECA3 1.13	Red
7	Rear lamps, clearance & side marker lamps	ECA3 1.13	Brown

Cable Entry View



7 Pin Socket

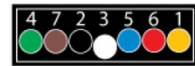

7 Pin Plug

50A GREY ANDERSON PLUG FITTED FOR CARAVAN CHARGING

Location: Front of drawbar

The GREY Anderson plug is for connection to the car. This is run directly to the DC/DC charger that stops the power from the caravan battery being sent back to the car battery. It is critical that you do not plug anything other than a vehicle alternator into this Anderson plug. Its also recommended to cable tie this to your trailer plug to provide support should it become disconnected from the car, preventing it dragging on the ground.

50A RED ANDERSON PLUG FITTED FOR PORTABLE SOLAR PANELS

Location: On the wall extrusion next to the water fillers underneath

An additional RED Anderson plug is fitted for connection of portable solar panels. This Anderson plug is connected to the DC/DC charger and then to the batteries. Your portable panel must have the regulator removed or bypassed for the solar panel to work with the Redarc DC/DC charger. This plug is different to the standard grey plug you have fitted to the drawbar. So make sure your portable solar panel has a RED Anderson plug installed.

GAS SYSTEM

Your ZONE RV is fitted with a LPG gas system. This system is tested by a qualified Gas Certifier & fitted with a Gas Certification Plate located inside the gas bottle storage box. LPG is a volatile fuel system and by its composition extremely explosive so great care needs to be taken when doing anything with your gas system.

GAS VENTING

Location: At front of the bed base

Your caravan is permanently vented through the floor underneath your bed. There is access to this venting through the front of the bed base with the thumb screws. The raw fibreglass is finished with a plastic round insert to stop the glass sheeting from splintering. They also have a thread in them, but Zone RV does in NO WAY condone using a cover in these vents in any form. If you have closed these vents off prior to traveling on dusty roads, then we strongly suggest you turn your gas bottles OFF and DO NOT turn them on again until you have removed the covers.

GAS ALARM

Location: Behind lounge gable down low.

This is a back up safety system to alert you to any gas leak in your van. This alarm is dormant for 3 minutes after start up so we suggest making sure this is powered up for 5 minutes before you turn your gas bottles on.

If the alarm goes off and you can smell gas, exit the van immediately, turn your bottles off and call for help.

If ANY gas appliance is removed or any gas connection tampered with you **MUST** get a new Gas Compliance Certificate otherwise your van warranty will be void.

SELECTING A GAS BOTTLE

On the front of your van is a dual bottle regulator. To select one of the bottles simply turn the selection valve towards the bottle you wish to draw from. Then open that bottle. If removing the bottles, there will be some gas back pressure from the system so ensure there is no naked flame within 5 meters of gas bottle storage box.

ISOLATING AN APPLIANCE/OUTLET:

Cooktop - Underneath the oven behind the service panel.

Hot Water System - Underneath Vanity & rear of caravan.

External Gas Bayonet - Behind the front p/s tunnel boot locker. (only use approved appliances).

NOTE: If annexe fitted, we recommend isolating the bayonet line when not in use.



POWER SYSTEMS

ELECTRICAL CERTIFICATE

All the ZONE RV caravans are supplied with a non-prescribed Electrical Certificate. Installation and testing of 240V cabling and components is completed by a qualified Electrician. Any change to this system will void the certification and 240V warranty.

12V POWER SYSTEM

Run from the battery and controlled/monitored by the RED VISION display. This system will run your Sirocco fans, entertainment, roof fans, airbag controls, water pumps and fridge along with the 12V outlets. The REDVISION display will tell you the Amps in or Amps out depending on whether you have more or less charge than you are using. This varies depending on charge conditions i.e. solar input and the load on the batteries e.g. amount of 12V appliances you're running.

To check your charge, turn all 12V appliances off (including fridge) and read the gauge. You can expect in normal operation for your fridge compressor to be running 80% of the time so the general rule is that it will use 100A per 24 hour period.

Lithium batteries have their own fail safe and therefore CAN be drained until the low voltage cut out initiates, but as always this is not recommended.

NOTE: For a 200Ah lithium battery to reconnect after the low voltage cut out has engaged (this will show 0 volts on readouts) a charge voltage of $\geq 12.8V$ must be applied to the battery BEFORE the low voltage cut out will de-activate and allow charge current to flow into the battery.

INVERTER

The battery will be supplying the inverter with 12V to convert it to 240V, so using 240V appliances on the inverter will drain your battery.

240V POWER SYSTEM

The 240V system is only available if you have 240V power plugged in from an external source or you have optioned up to have a 3000W inverter. This can be at a caravan park or from your generator. This will automatically provide power to all 240V outlets in your van, 240V power point behind the fridge (for AC charger) A/C, washing machine, hot water service and fridge.

IMPORTANT INFORMATION

If supplying 240V to your ZONE RV with a generator, you will need to load shed. This means turning off the hot water 240 switch. If using a low-capacity generator, you may need to turn off the 240V point behind the fridge for the battery charger if you want to run your A/C.



REDARC DIGITAL MANAGEMENT SYSTEM

REDARC REDVISION DISPLAY

Location: Side of the overhead cupboard at the front door or rear door above bench top.

Red Vision brings information and control right to your fingertips to switch features like your lights, fridge, TV, inverter and more on or off using the wall display or handy app on your phone. It even gives you information on water levels, temperatures, and when paired with a Manager30 Battery Management System, you also get instant feedback on your auxiliary battery and electrical system.



Please refer to REDARC user manual for more information about using or customising your REDVISION display.

Please find the user manual in the folder supplied at handover.

If you are having any issues with you REDVISION display, please contact a Redarc support technicians on the details below.

P: (+61) 1300 733 272

REDARC REDVISION DISPLAY – MOBILE APP

You can control your Red vision display and manager system from your mobile device. Using the RedVision app on your smartphone, when paired correctly with a distribution box, you can:

- Turn devices on or off such as lights, inverter, water pump and any other load demands like TV, electric steps, fridges and more.
- Monitor water tanks, temperature settings, energy consumption (battery power) and storage
- Automate functions in your ZONE RV. For example, hit one button and turn everything off except the fridge leaving it running.

Other key features

- Communicates via Bluetooth with smart phones
- REDARC quality and aftersales support
- Australian designed and manufactured

You can download the Redarc Red vision app from the Apple store or Google Play.



Click below to download.



REDVISION TOTAL VEHICLE MANAGEMENT SYSTEM

REDVISION SCHEMATICS SYSTEM LAYOUT

Location: Inside of the REDARC service panel – Drivers side

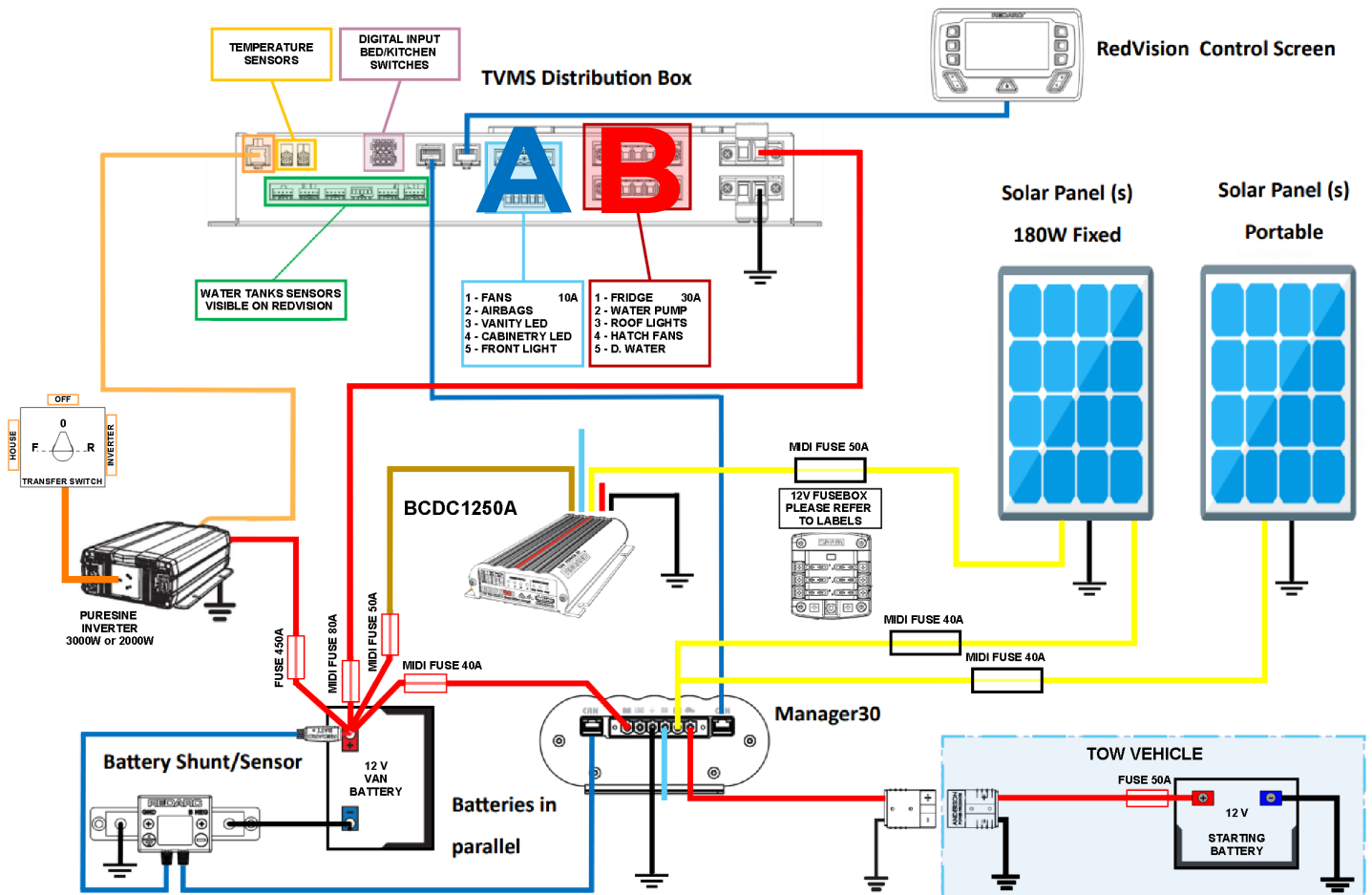

A – 10A Max Circuit Fuses

1. Fans
2. Airbags
3. Vanity LED
4. Cabinetry LED
5. Front Light

B – 30A Max Circuit Fuses

1. Fridge
2. Water Pump
3. Roof Lights
4. Hatch Fans
5. D. Water

INVERTER

REDACR INVERTERS 2000W OR 3000W

Location: Inside of the REDARC service panel – Drivers side

1. 2000W Inverter



2. 3000W Inverter (UPGRADE)



Please find the user manual in the folder supplied at handover.

To connect your ZONE RV to mains 240V, you will need to switch the “change over switch” to setting “1 – Mains”. To use the inverter for 240V, you will need to switch the “change over switch” to setting “2 – inverter.”

Please refer to the **“240 RCD Switch Schematic”** for reference.

CHARGER

REDARC 50A BC DC BATTERY CHARGER

Location: Inside of the REDARC service panel – Drivers side



The REDARC 50A BCDC Charger receives charging from the following sources to charge the 12v system in your ZONE RV.

- Fixed solar pannels on the roof
- From your tow vehicle

For further information about this, please refer to **REDVISION Schematics System.**

240 RCD SWITCH SCHEMATIC

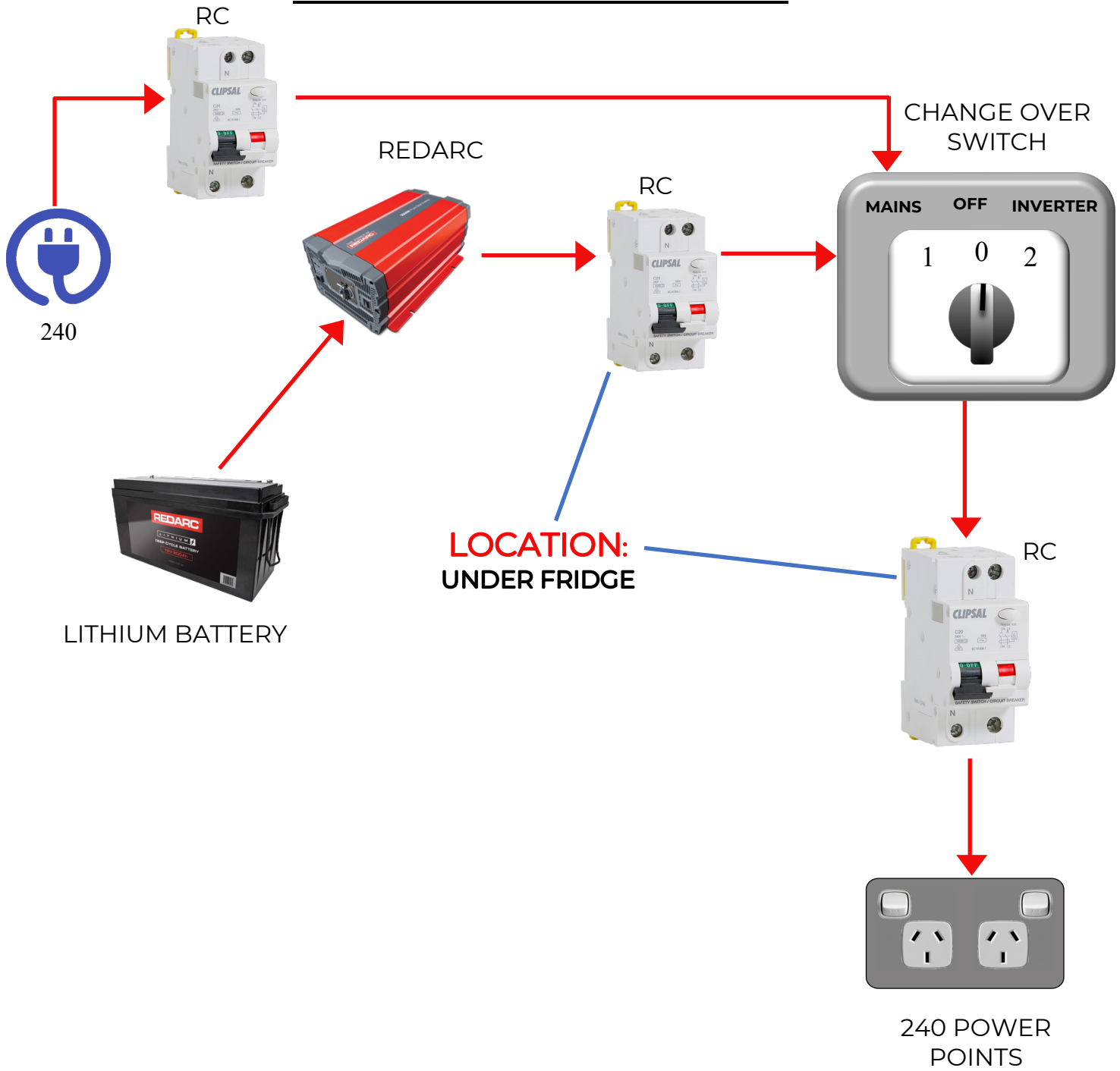

PLUMBING SCHEMATIC

STANDARD PLUMBING

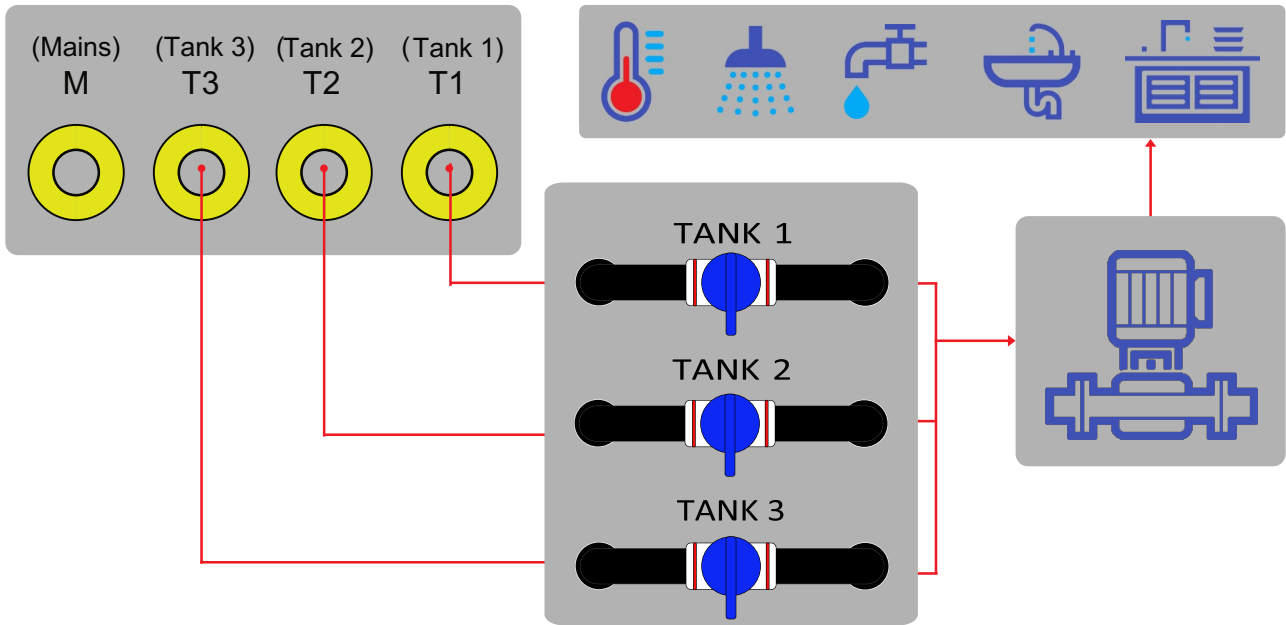

PLUMBING UPGRADE – ISLOATED DRINKING TANK

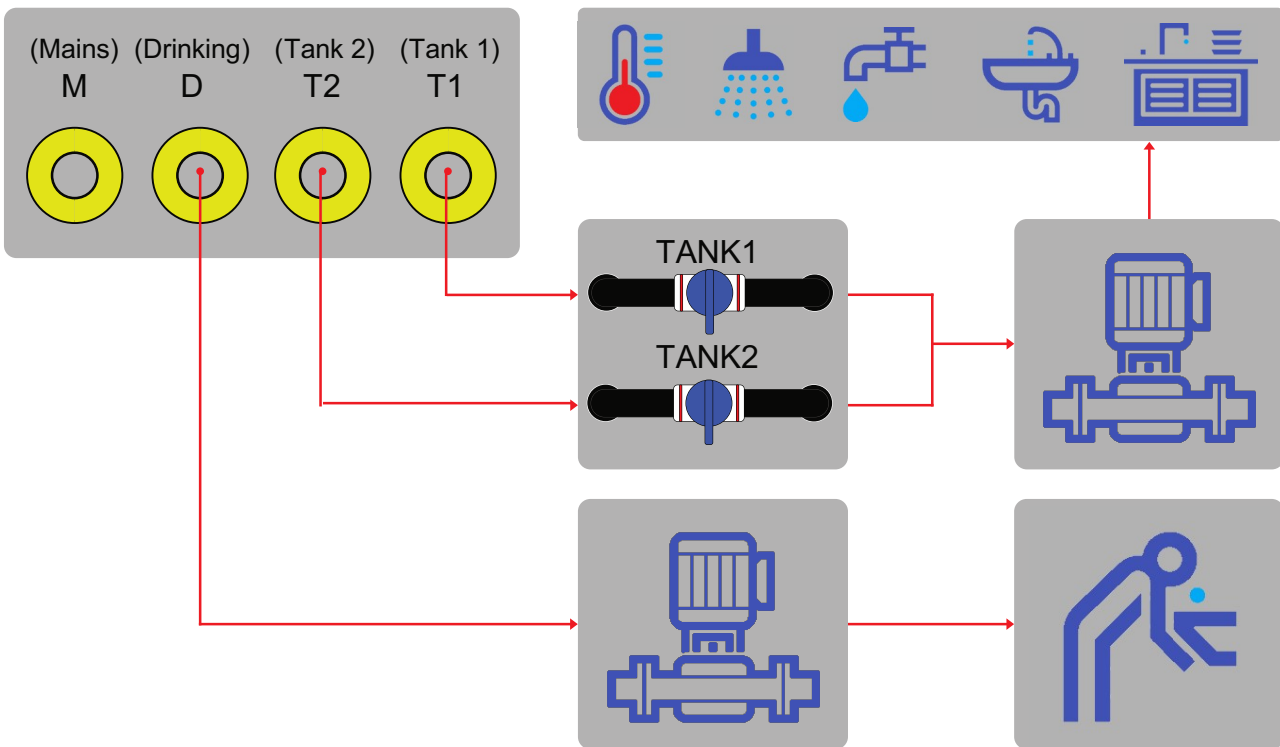

PLUMBING SCHEMATIC

WATER TANKS

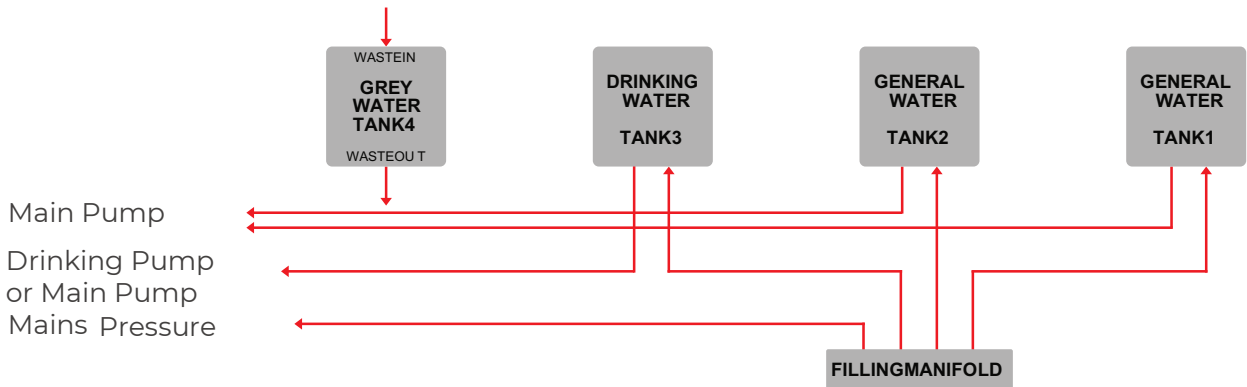

PLUMBING LAYOUT IN SERVICE AREA

Location:

Standard Layout: Behind the inspection panel next to the toilet.

Bunk Layout: If you option for bunks it'll be in the washing machine cabinet

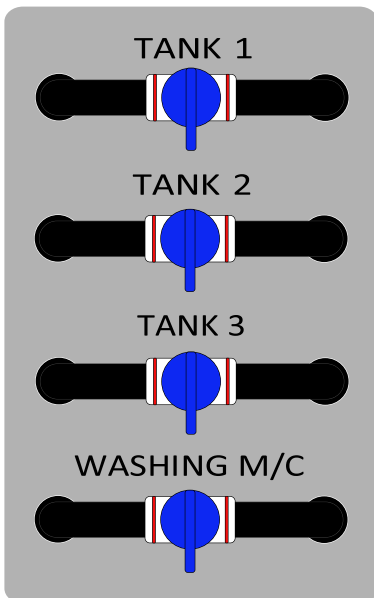

WATER PUMP

Diaphragm access (See pump manual for service)



Check filter for obstructions, regular cleaning required

NOTE: Before turning on the water pump, make sure you have selected which tank you want to draw from at the pump panel as pictured above. This stops risk of your water pump running dry and seizing.

PLUMBING GENERAL

WATER FILTERS

Location - Your standard water filter is mounted behind the inspection panel next to the toilet or under the centre seat in a rear lounge model. If you have optioned up to a bunk, the water filter will be mounted in the washing machine cabinet. If you've had a dedicated drinking water tank fitted, another will be located under the kitchen sink. The standard water filter is fitted after the tank fill as the water is being drawn from the tanks into the caravan this will filter the water used. The Aquapro AIC-K filter will require replacement after approx. 12 months and can be purchased from Zone RV or www.mywaterfilter.com.au

NOTE: If you find that your caravan water pressure has depleted, remove your water filter and back flush to remove any debris.

WATER CONNECTION MANIFOLD

Location: Drivers side of caravan, behind rear wheel

Standard Option

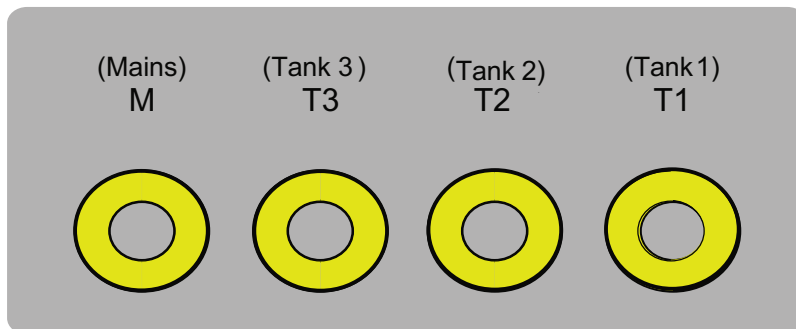

Upgraded Option – Isolated Drinking Tank

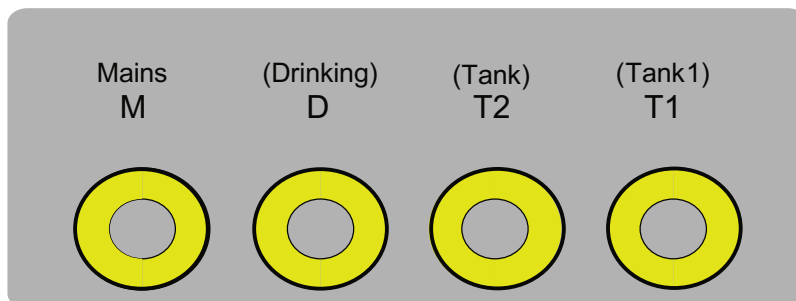

PLUMBING GENERAL

FILLING YOUR WATER TANKS:

- Ensure your tanks aren't already full by checking the tank gauge on your REDARC display.
- Plug a hose onto the inlet for the tank you wish to fill. Visual inspection required when filling in case breathers are blocked, making sure tank isn't expanding.
- Do not fill with full mains pressure, only half pressure, so only open the tap partially. This ensures the breathers on top of the tanks can keep up with the amount of water entering the tank.
- Keep an eye on the level display to make sure the correct tank is filling, and you do not overflow the tank.
- When your tanks get close to full, you might notice a little overflowing coming from the breather holes located in each tank.

NOTE: If you over fill the tank, water will be forced out the tank breathers and onto the ground. If this happens, stop filling the tank and give it time to relieve the pressure in the tank.

MAINTENANCE

It is good practice to periodically wash off the top of your tanks to remove any build-up of dust/dirt that may accumulate after long periods of dirt road travel. Also inspect the tank breathers for obstruction. Keep rubber caps on the inlet connectors when not in use.

PUMP OPERATION:

- Pump will engage when any tap is turned on.

NOTE: Pump is not required when on mains pressure as it is bypassed straight through the filter.

DRAINING YOUR WATER TANKS:

- Each water tank has it's own bung that can be removed.
- They are located on the side underneath the chassis.
- Just simply unscrew anti-clockwise to let the water flow
- When replacing the bung, ensure it is done up hand tight



out.
only.

NOTE: Do not use a tool as you may strip the bung thread.

PLUMBING GENERAL

DRAINING YOUR GREY WATER TANK:

Location: Drivers side of van, behind rear wheel.

- Attach the supplied grey water hose to the cam lock fitting.
- Turn the valve to the open position.

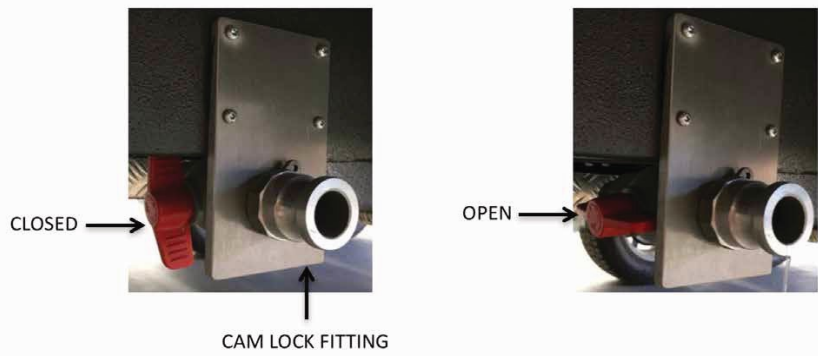

NOTE: Only empty grey waste tank at specified dump stations.

GREY WATER BY-PASS (if fitted)

Location: Drivers side of van, behind rear wheel, next to grey water

- Attach the supplied grey water hose to the cam lock fitting.
- Turn the valve to the open position.

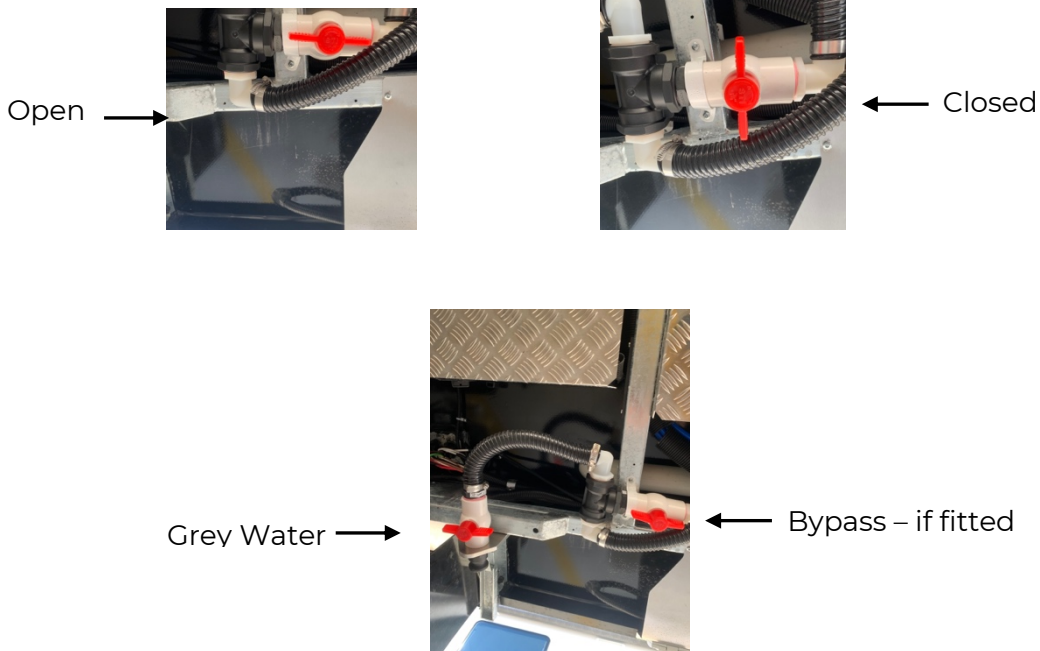

PLUMBING GENERAL

Standard Option

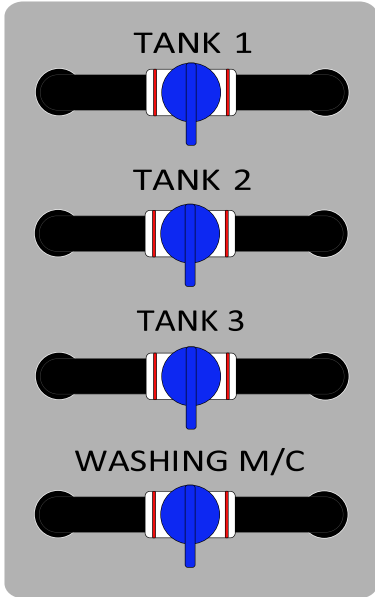

Optional Upgrade - Isolated Drinking Tank

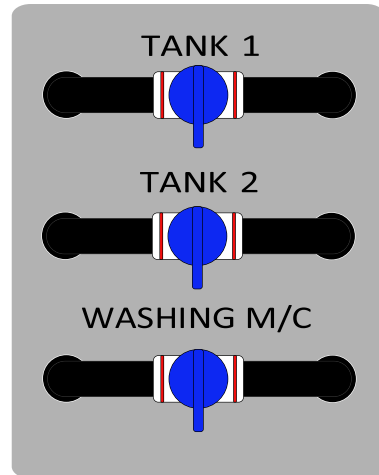

NOTE: Isolated drinking water tap is under the sink in

SEAFLOW EXTERNAL WATER PUMP

WATER PUMP:

The Seaflow water pump is an external pump supplied with you caravan to fill your water tanks when you have no access to mains water supply.

NOTE: Water must be potable if going into drinking water tank.



FILLING TANKS WITH WATER PUMP

1. Put strainer into water supply
2. Ensure the inlet hose is connect to inlet
3. Connect coiled hose to desired filling tank
4. With dry hands, connect wiring harness to the grey Anderson plug under the water fill points.
5. Once Anderson plus are connected, water will begin flowing into tanks.

FEATURES & BENEFITS

Tool case, easy to use, store and carry on.

2.4m wiring harness for car cigarette charger.



6.5m UV-protected coiled hose coil.

Adjustable spray gun, idea for cleaning leisure boats, fish boxes, anchor chains and dinghies.

For more information, please refer to Seaflow Wash Down kit manual.

COMPRESSOR FRIDGE/ FREEZER

GENERAL MAINTENANCE & TIPS

Cleaning:

Wash the inside of your fridge with warm water and a mild soap. Never use abrasive or corrosive cleaning agents, steel wool or scouring sponges. A soft sponge, towel, or soft brush is recommended.

Always keep the inside of the fridge clean and dry. Remove any condensate water or ice which gathers in or near the tray under the freezer compartment.

Be careful when opening or closing the freezer door if ice has been allowed to accumulate in this area.

Keep the doors of the fridge ajar when the fridge is not in use, to allow fresh air to circulate inside the fridge compartment.

Defrosting:

Defrosting needs to be carried out when the ice layer reaches a thickness of 5mm. Turn the fridge power off and move your food and beverages to another cool place. Do not use any objects to remove the ice or frost, it must be allowed to melt naturally. Once the ice has melted, dry the inside of the fridge and freezer compartment thoroughly.

Energy Saving Tips:

- Have as much ventilation as possible - the more the better.
- Keep the fridge out of direct sunlight whenever possible.
- Only open the fridge or freezer door when necessary.
- Allow hot food to cool down before placing inside fridge.
- Defrost the fridge as soon as a layer of ice forms.
- Set the fridge to be only as cold as necessary.

NOTE: Please refer to the product manual for further instructions.



ENTERTAINMENT ACCESSORIES

TV WALL PLATE:

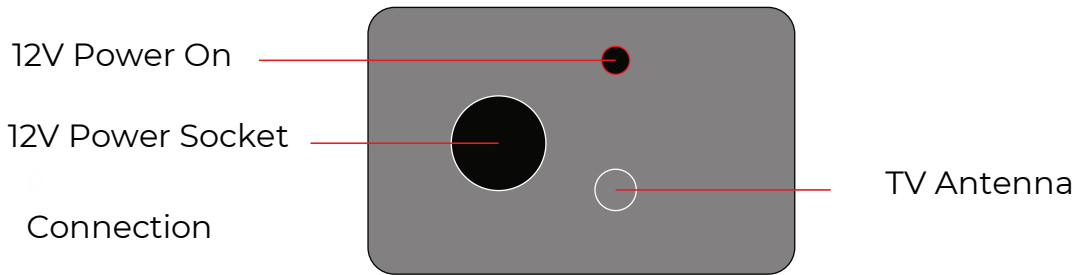

HDMI PLATE:

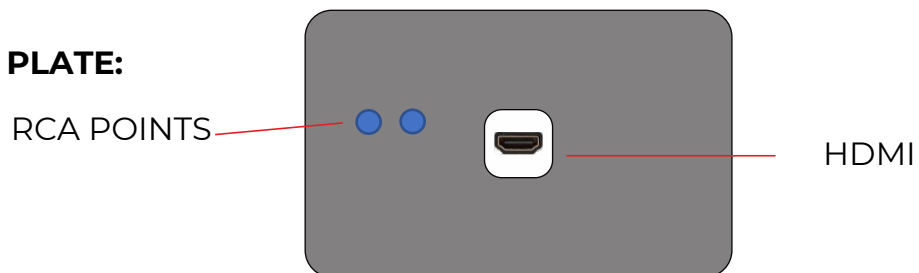

240V POWER POINT:

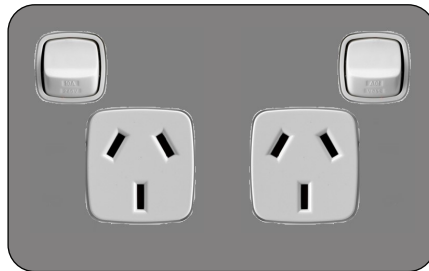

SUSPENSION SYSTEM

XT AIRBAG SUSPENSION



ATX AIRBAG SUSPENSION (DRUM BRAKES) - UPGRADE



ATX AIRBAG SUSPENSION (DISC BRAKES) - UPGRADE



SUSPENSION SYSTEM

CRUISEMASTER XT SUSPENSION



SETTING RIDE HEIGHT

To achieve the best possible ride, it is important to correctly set your suspension ride height. This allows for the correct amount of travel and for all components to be operating as designed.

As this system is designed to allow for differing loads the best way to measure and set ride height is as per below.

HEIGHT SETTING METHOD

Measure the vertical distance from the bump stop to the strike plate.

This measurement will vary depending on the airbag used in your system.

2.8T Tandem = vertical gap of 65mm

(Airbag Ref: AB 0121-V)

3.4T Tandem = vertical gap of 75mm

(Airbag Ref: AB 0136-V)

4.5T Tandem = vertical gap of 85mm

(Airbag Ref: AB 0140-V)

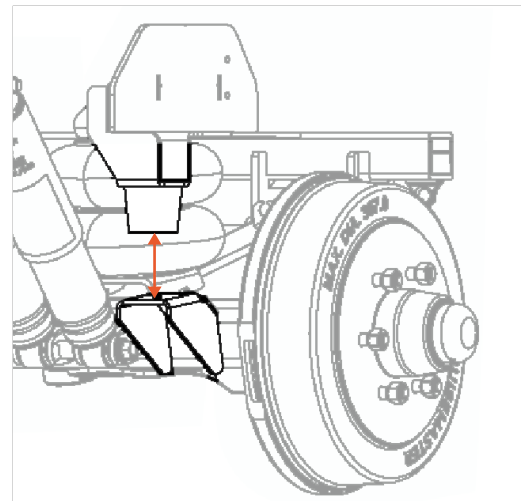

OPERATING AT NON-STANDARD HEIGHT

It is permissible to use the air springs to level the vehicle on site when stationary. This should be done with the brakes off but with the vehicle safely secured (eg: attached to the tow vehicle).

If it is required to raise the vehicle above the normal ride position, then speed must be limited to 10kph and under.

SUSPENSION SYSTEM

CRUISEMASTER ATX SUSPENSION

SETTING RIDE HEIGHT

To achieve the best possible ride, it is important to correctly set your suspension ride height. This allows for the correct amount of travel and for all components to be operating as designed.

As this system is designed to allow for differing loads the best way to measure and set ride height is per below.

HEIGHT SETTING METHOD

Measure the distance from lower eyelet to upper eyelet of the rebound cable mounts (as shown).

360mm from eyelet to eyelet will give you the optimised ride height for the load being carried.

For easy confirmation of ride height, we recommend the use of "Cruisemaster" "Ride Height Indicators" as a visual marker in the wheel arch to line up with the tyre. This will eliminate the need to remeasure the spacing on every adjustment.

OPERATING AT NON-STANDARD HEIGHT

It is permissible to use the air springs to level the vehicle on site when stationary. This should be done with the brakes off but with the vehicle safely secured. (e.g., attached to the tow vehicle).

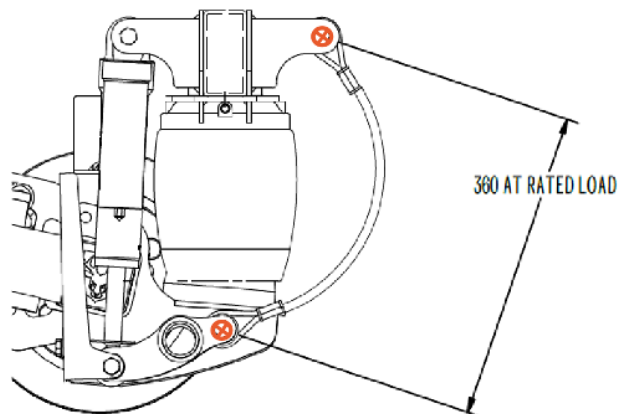

SUSPENSION SYSTEM

CARAVAN/ TRAILER STORAGE

If storing your vehicle for long periods, the suspension can be set to below standard ride height for improved access/ clearance. It is normal for air pressure to be lost during long term storage of your caravan causing the suspension height to lower

STORAGE

If storing your caravan for long periods, the suspension should be set at normal "Travel" height to protect the bump stops and air bags from compression damage.

OPERATING IN THE "GET YOU HOME" MODE (EMERGENCIES ONLY)

In the event of air loss, it is possible to run the caravan on the bump stops. The "get you home" feature of the suspension has been successfully used on normal roads. Extreme care and very slow speeds are required if running with airbags deflated. Off-road conditions especially can cause damage to airbags and drawbar mounting brackets. It may be advisable in these circumstances to lower tyre pressures to provide additional cushioning to road bumps.

NOTE: Warranty does not apply under these conditions



SUSPENSION SYSTEM

AIRBAGS

NOTE: If the compressor has been off for some time, it will need a few minutes to fill the air tank before you can pump the airbags up.

TRAVEL HEIGHT: The critical function for the correct traveling arrangement is the HEIGHT of the caravan, NOT the airbag pressure. Below is a diagram of the correct way to measure height for travel. This shows the top of the bump stop to the bottom of the chassis rails.

Cruisemaster XT Air has three different travel heights depending on the axle load capacity. This information is located on the Cruisemaster identification plate fixed to drawbar.

NOTE: Your airbag pressure will likely be different from side to side when setting this up and that is normal.

The normal operating PSI range is 45-60. Anything more than this can show overloading in your caravan or incorrect travel height. Traveling with the airbags higher or lower than these PSI settings can result in damage of your ZONE RV and may not be covered under warranty.

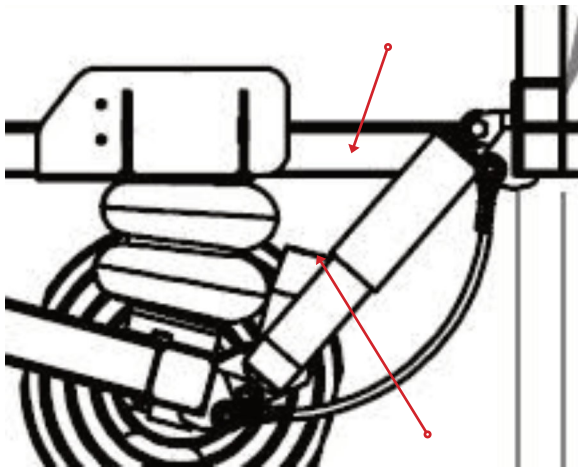

BUMP STOP



RIDE HEIGHT

TOP OF TYRE

SUSPENSION SYSTEM

AIRBAG CONTROL PANEL – MANUAL LEVELING

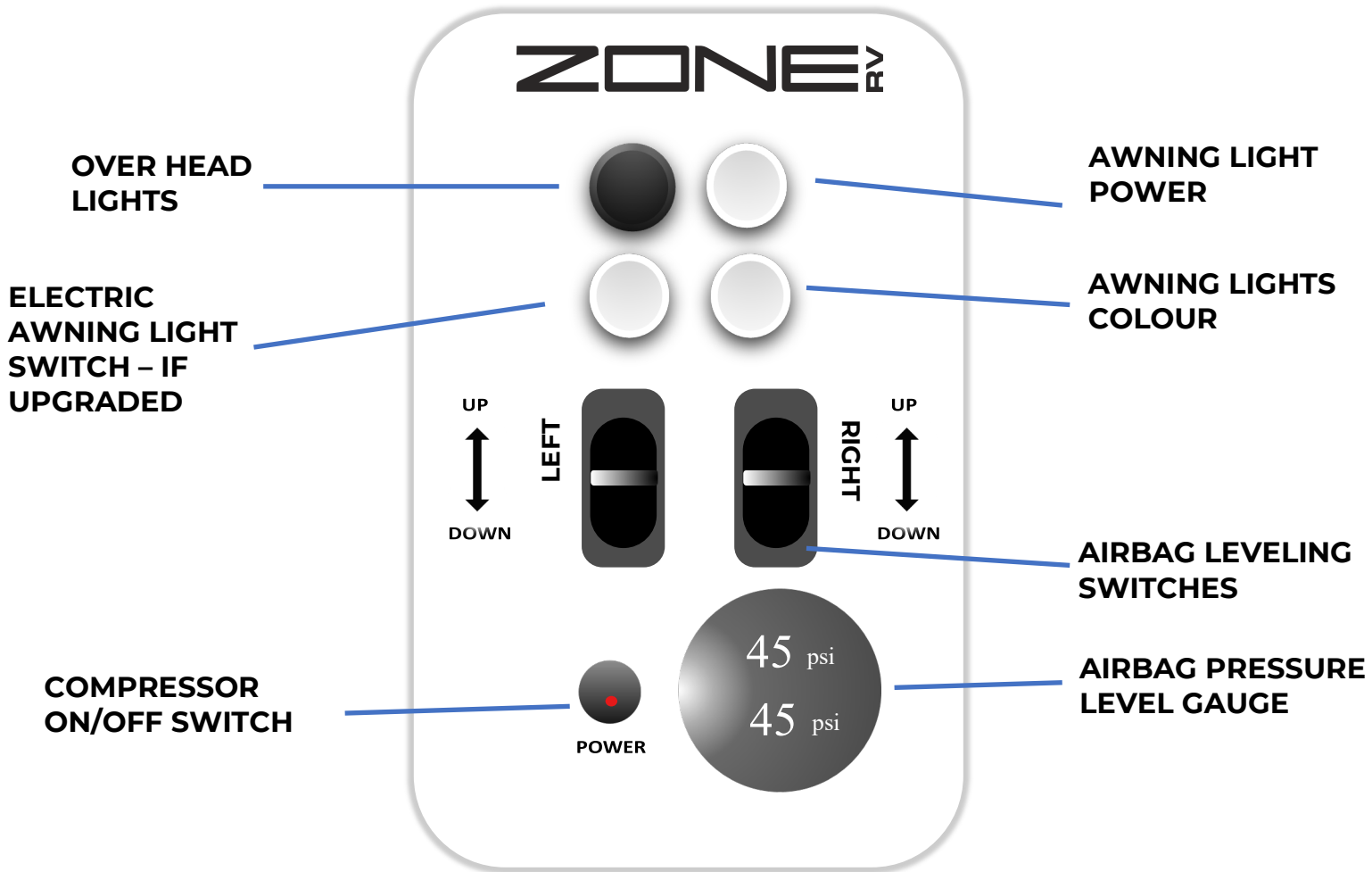

SUSPENSION SYSTEM

AIRBAG CONTROL PANEL – AUTO LEVELING AIR BAGS.

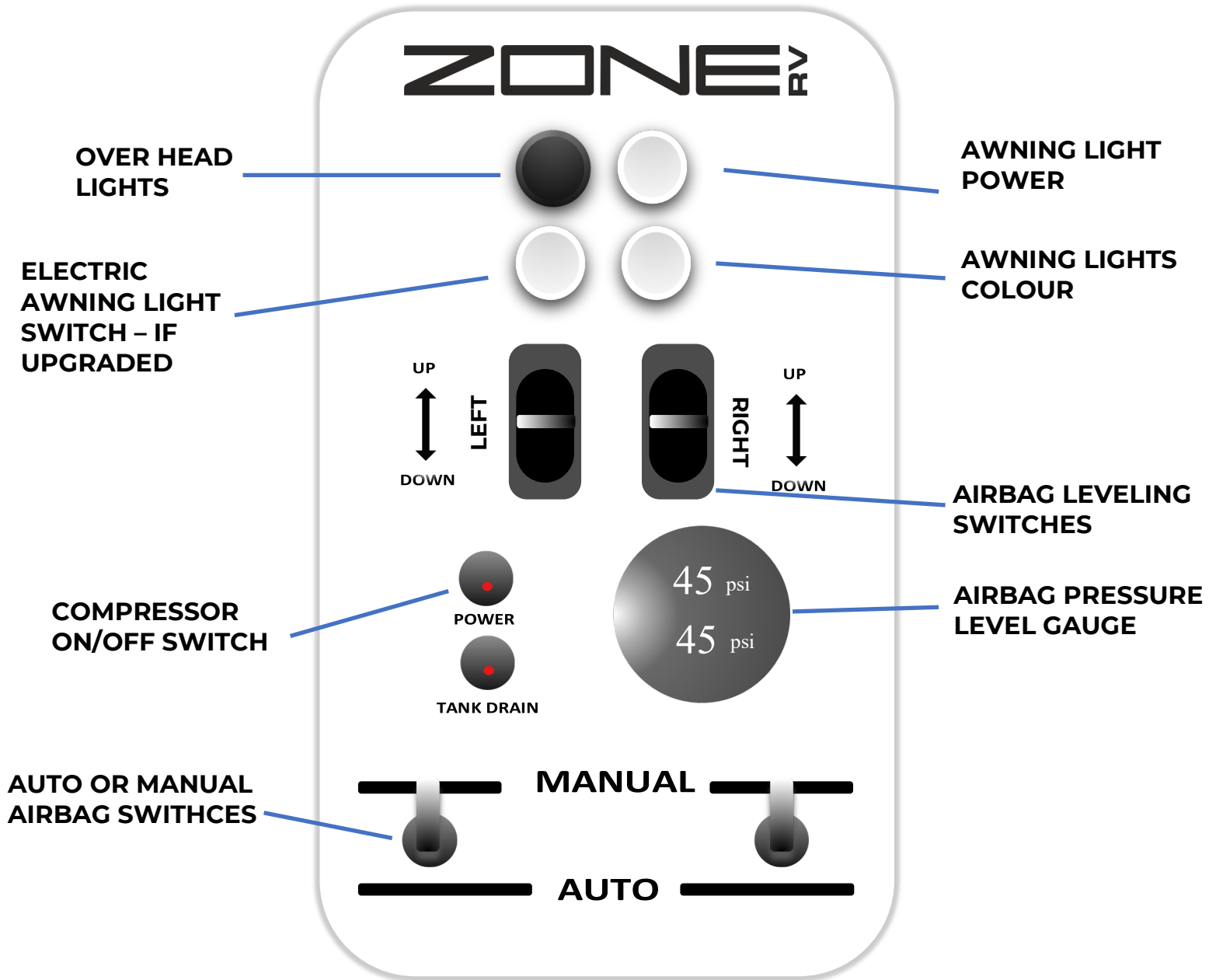

MAINTENANCE

DRUM BRAKE ADJUSTMENT

The electric brakes fitted to your ZONE RV are self-adjusting, but they may need to be manually adjusted from time to time.

To do this, jack one wheel up at a time on a level concrete floor. Chock the opposite wheel and the jockey wheel front and back and release the hand brake. Give the caravan a good push back and forth when it is on the jack to make certain it is stable and safe. Otherwise hitch up to your tow vehicle, this will ensure trailer cannot move. If installed remove the two plastic caps on the lower section of the backing plate, with a flat bladed screwdriver. There is a notched ratchet wheel about 2 cm inside this slot which is the adjuster. Rotate this adjuster as shown in the diagram below. Adjust the brakes up until they start to grab on the drums and back them off exactly 10 notches until the wheel rotates freely.

Repeat the process on the other side.

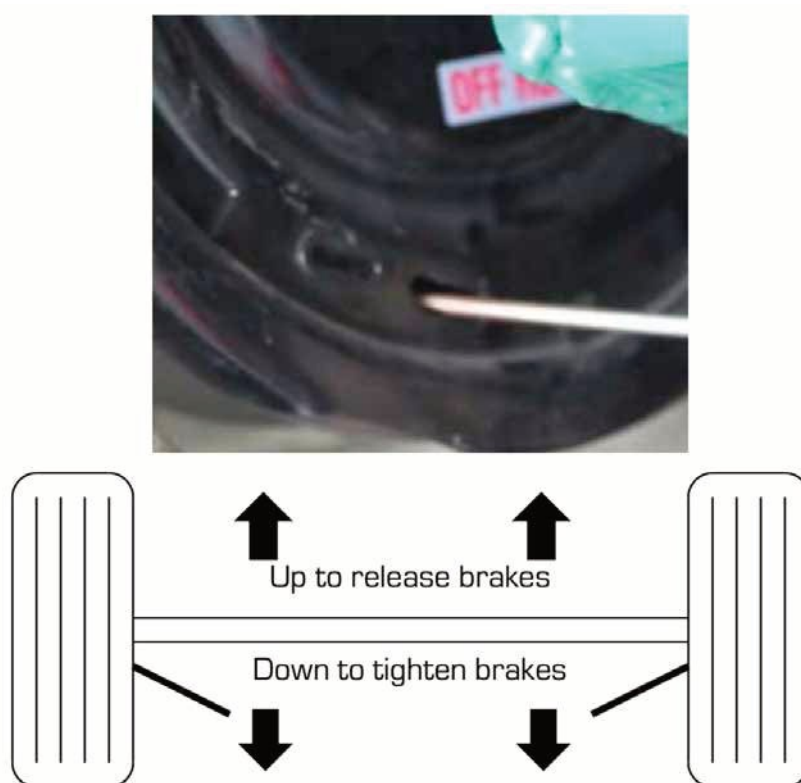

Insert screwdriver into slot, engage into adjuster and lever downwards to adjust up brakes or upwards to release brakes.

MAINTENANCE

SAFE JACKING

- Park the trailer on firm and level ground
- Chock the trailer tyres on the opposite side securely so that no forward or rearward movement is possible.
- Jack up the trailer directly under shock absorbers at lowest point on swing arm as shown below.
- Secure the trailer on jack stands of adequate capacity front and rear.

Cruisemaster ATX - Jacking Points



Cruisemaster XT - Jacking Points



REMOVING THE WHEEL HUB

If you need to remove the hub, follow these instructions:

- Undo the wheel nuts and remove the wheel.
- Pry off the dust cap using a flat bladed screwdriver.
- Straighten out the split pin that holds the bearing nut and remove it. Remove the bearing nut and washer.
- Gently pull the brake drum forward while cupping the hub opening with your hand to keep the front bearing from falling to the ground. The outer race stays in the drum, while the inner race and roller bearings come out as an assembled unit.
- Place the front bearing, bearing nut and the bearing washer in a clean container so as not to contaminate

NOTE: It is recommended that you get a qualified mechanic to do any bearing servicing

MAINTENANCE

WHEEL HUBS

Always check the hub temperatures at least twice a day when traveling. They should be warm to your touch. If one side is constantly hotter than the other then have them checked immediately by a Mechanic or Service Agent.

When traveling on dirt roads, check hub temperatures every time you stop/every hour. When traveling on dirt roads check wheel nuts every morning before departure without fail, on both tow vehicle and trailer.

If brakes or hubs become excessively noisy, hot or are grabbing, have them serviced by a motor mechanic or service agent.

NOTE: This document is only a guide. Zone RV recommends that all service work should be carried out by a qualified mechanic.

CHECKPOINTS AFTER A SHORT TIME ON THE DIRT

Generally, 30min intervals are good to check your van to see if anything has worked loose. This is a good practice until your confident all the fastenings have bedded in and are holding. During this check also ensure there are no areas showing signs of dust ingress.

DUST INGRESS

Silicon Seals: Although your van has been fully sealed during production, there is a small chance the glues/sealants may have moved and now allow some dust ingress. Its always good practice to travel with a tube of silicon sealant for the unlikely need to re-seal.

External Hatches: It is good practice to periodically check that your external hatches are sealing correctly. It may be necessary to adjust the locking lever from time to time.

BEACH USE

After driving on the beach or camping near salt air, wash your van thoroughly and apply a liberal coating of Innox or WD40 to all steel, stainless steel and aluminium surfaces. Allow to soak in for 24hrs and wipe off residue or wash off with car wash.



MAINTENANCE

FRONT DRAWER PANEL ADJUSTMENT

Location: Behind plastic side covers.

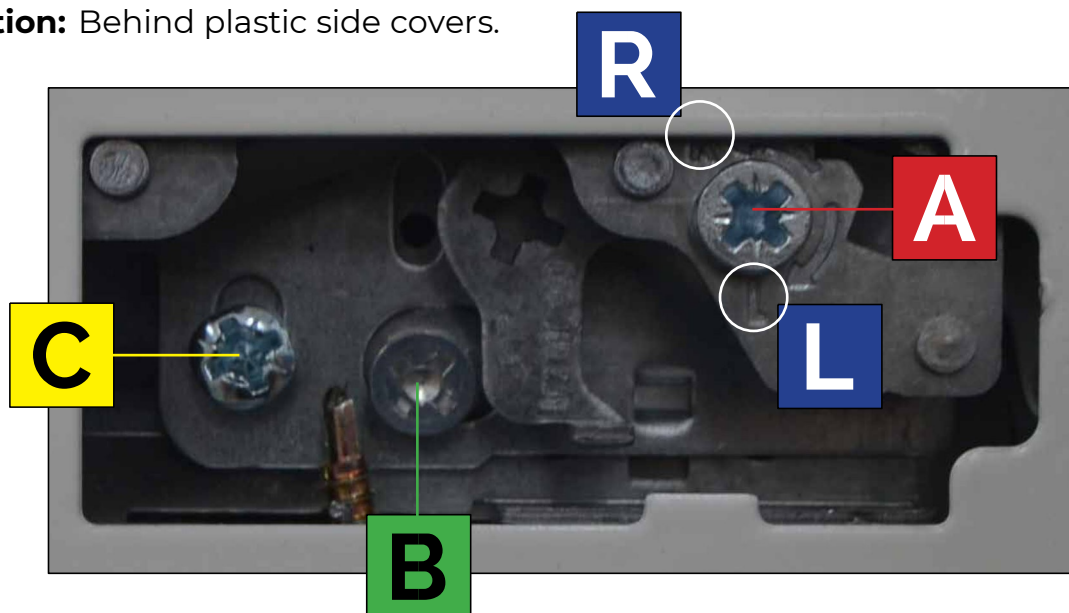

MOVING PANELS TO THE RIGHT - R

1. Open drawer
2. Remove covers located on either side of side panel.
3. Insert tool into position **A**
4. Turn towards **R**
5. Adjust panel to the right

MOVING PANELS TO THE LEFT - L

1. Open drawer
2. Remove covers located on either side of side panel
3. Insert tool into position **A**
4. Turn towards **L**
5. Adjust panel to the left

MOVING PANELS UPWARDS - U

1. Open drawer
2. Remove covers located on either side of side panel.
3. Loosen locking screw **C**
4. Insert tool into position **B**
5. Turn anti clockwise on left side and clockwise on right side

MOVING PANELS DOWNWARDS - D

1. Open drawer
2. Remove covers located on either side of side panel
3. Loosen Locking Screw **C**
4. Insert tool into position **B**
5. Turn clockwise on left side and anti-clockwise on right side

PREPARING FOR OFF-ROAD

THINGS TO CHECK

As with any vehicle regular checking and visual inspections before and during OFF-ROAD driving is required on your ZONE RV. Although we take great care on selecting the correct fastenings methods, these are not infallible to the rigours of off-road driving. Below is a list of things to check before hitting the dirt:

- Check cupboard fastenings are tight. Draw latch fastenings in particular need to be tightened, check all fastenings with a Philips head screw driver
- Oven bolts through the cabinets are tight and not pulling into the cabinetry. Check fridge bolts and fastenings are the same. The majority of fastenings in your van are M6 Allen key heads or Torx head
- Battery straps are tight
- Check all fixtures for appliances and components like the water pump, solar regulator
- Make sure hinge mounts for cupboard doors are tight as loosening of these can allow the door to come open. Check all draws and doors are latched correctly
- Check fastenings for drawbar components are tight. Check toolbox bolts, gas bottle holders and jerry can holders are tight
- Make sure your Anderson plug is tight into the back of our car. Cable tie it to the trailer plug so if it comes out it doesn't drag on the ground
- Check all hatches are closing tight and adjust the hatch latch as required by applying force to it to tighten the hatch close
- Walk around your van and visually inspect to see if there is anything unusual. Any component that looks loose, or any areas of damage
- Check your tyre pressures and suspension height
- Ensure gas bottles are secure & turned off



DRIVING RECOMMENDATIONS

THIS IS A GUIDE ONLY

Some of the conditions that you may encounter during your travels can cause damage to your van if you do not take appropriate actions. ZONE RV has the following recommendations for some of these conditions, (note these do not account for traffic or weather conditions) Pressures shown are cold tyre pressures.

BITUMEN ROAD TYRE PRESSURE - 40 PSI (110KM SPEED LIMIT)

DUSTY ROAD TYRE PRESSURE - 35 PSI (100KM SPEED LIMIT)



LIGHTLY CORRUGATED

28 PSI (80 - 100km Speed Limit)



MODERATE CORRUGATIONS

23 PSI (80km Speed Limit)



BAD CORRUGATIONS 18 PSI (60km
Recommended Minimum Speed)

Where Possible, Maximum Speed 80km)

DRIVING RECOMMENDATIONS

SAND DRIVING:

- Reduce speed and reduce all tyre pressures on both the van and vehicle to 18psi or less
- Try to drive on the harder sand. Maintain the momentum of your vehicle while negotiating soft sand and stay in the wheel ruts as they are usually harder than the soft sand
- If your vehicle allows, select low range auto for beach access and high range 4WD for hard sand driving. It is advisable to turn the brake controller off as sudden stopping can bog the trailer

WATER CROSSING:

- Please pause or stop to allow cooling of your hubs and bearings before making a water crossing, this may prevent ingress of water through the wheel bearing seals
- After making water crossing, apply the brakes once on the track until braking is normal, or use the brake controller to apply the trailer brakes to dry out the linings
- Allow 20 minutes cooling of your bearings before river crossings. Always check and regrease bearings after crossings as required

Always check wheel bearings after water crossings



DEPARTURE CHECKLIST

INTERNAL CHECK:

- Turn off water heater/ diesel heater/ pumps
- Drawers locked
- All windows locked in closed position
- All window blinds are in open "Travel" position
- TV has been removed from wall mount secure position
- Lower main table into "Travel" position
- Roof hatches closed with blinds in open position, including shower hatch
- Fridge doors are latched closed
- Ensuite door is latched in "Travel" position
- Shower head is stowed on the floor wrapped in a towel or in bathmat.
- Aerial put into travel mode

EXTERNAL CHECK:

- Gas bottle valves are turned OFF
- Disconnect gas bayonet at external kitchen
- Store external kitchen and secure catches firmly (If Fitted)
- All hatches and doors, including glass entry door have been closed & clipped correctly
- Secure awning latches/catches and tighten black thumb wheels
- Stabiliser legs set to "Travel" position
- Entry step set to "Travel" position
- Disconnect water/ grey water/ grey water hoses
- Disconnect mains electricity cord if connect
- Ensure air bags are set to travel height.

SAFETY CHECK:

- Check safety chains & brake-safe lanyard are connected
- Check trailer & Anderson plugs
- Check lights, indicators
- Check coupling is secured & cap is on.
- Check jack is set in "Travel" position
- Check handbrake is released



DEPARTURE CHECKLIST

WHEEL NUTS/LUGS & BEARINGS:

- Check torque of wheel nuts before departure, to ensure they are
NOTE: It is your responsibility to check the wheel nuts prior to each trip
- It is advised to check & re-grease the wheel bearings after immersing the axles in water. If you have done a large trip that includes traversing water crossings a wheel bearing service is required

VIN/COMPLIANCE PLATE, TARE & ATM:

- ATM or maximum load capacity can be found on the VIN plate in the tunnel boot
- Also on that VIN plate is your TARE weight, tyre size and recommended road pressure for your tyres

EXCEEDING THE CARAVAN'S ATM & BALL WEIGHT IS ILLEGAL AND DOING SO WILL VOID YOUR WARRANTY AND MOST LIKELY INSURANCE

CARAVAN WELDING:

- If any welding is required to be carried out on your caravan chassis, the batteries MUST be disconnected, including the negative connection
- The Hot Water System circuit board (if installed) must also be removed prior to this task; including earth connection
- When welding is complete, reinstall heater circuit board, then reconnect the batteries



AFTER-SALES SERVICE DEPT CONTACT

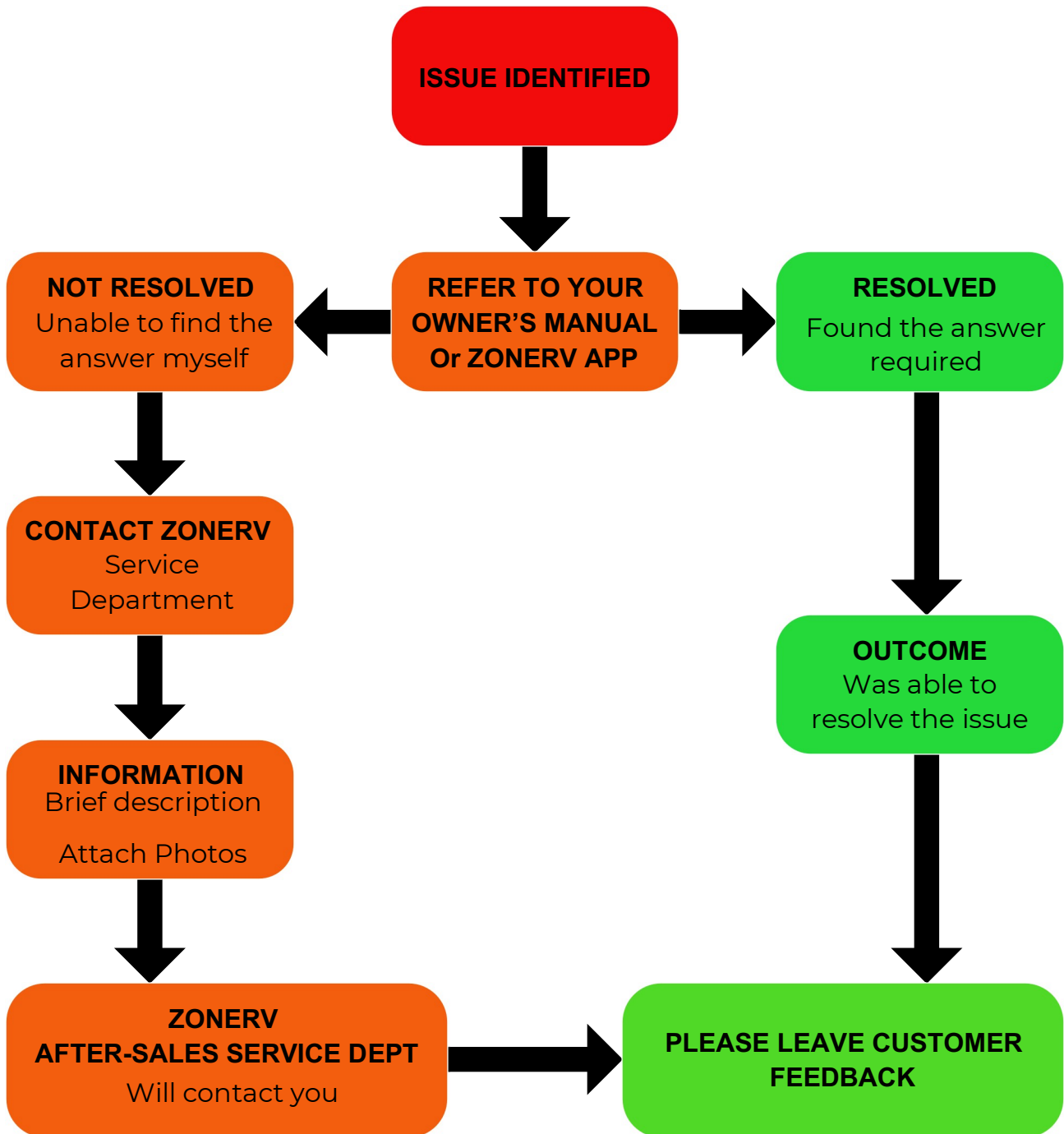

ZONE RV AFTER-SALES SERVICE DEPARTMENT

A: 85 Quanda Road, Coolum Beach, QLD 4573

P: (07) 5471 6410

E: service@zonerv.com.au

W: www.zonerv.com.au



DISCLAIMER

The content of this manual is provided for general information purposes and is a guide only. Every effort has been made to provide accurate information. However, you must make and rely on your own assessment of your situation to determine the suitability and usefulness of this information. Accordingly, Zone RV makes no representations, warranties or guaranties, either expressed or implied, regarding the suitability of usefulness of this information. Zone RV accepts no liability for any loss, damage, claim or expense suffered by you arising from your use of or reliance on the information provided in this manual.



CUSTOMER NOTES



CUSTOMER NOTES

